

Master thesis in software engineering and management



IT University
of Göteborg

CHALMERS | GÖTEBORG UNIVERSITY

Unwired Enterprise Systems

Naveed Hussain
Göteborg, Sweden 2007

Department of applied information technology

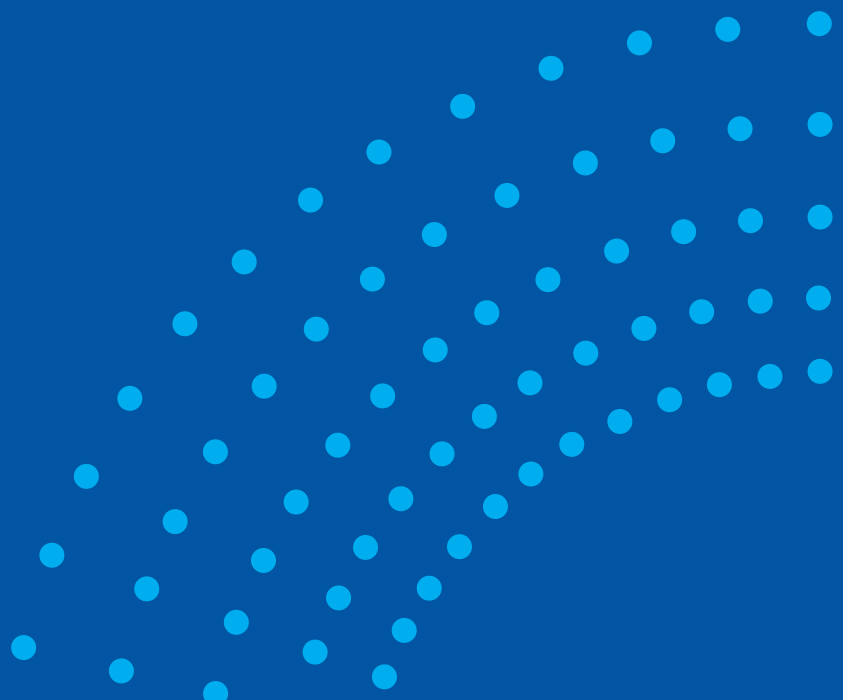

REPORT NO. 2007: 111

UNWIRED ENTERPRISE SYSTEMS

Naveed Hussain



Department of Applied Information Technology
IT UNIVERSITY OF GÖTEBORG
GÖTEBORG UNIVERSITY AND CHALMERS UNIVERSITY OF TECHNOLOGY
Göteborg, Sweden 2007

Unwired Enterprise Systems

Naveed Hussain

© Naveed Hussain, 2007

Report no 2007: 111

ISSN: 1651-4769

Department of Applied Information Technology

IT University of Göteborg

Göteborg University and Chalmers University of Technology

P O Box 8718

SE – 402 75 Göteborg

Sweden

Telephone + 46 (0)31-772 4895

Göteborg, Sweden 2007

Preface

I would like to dedicate this thesis to my grand father Mr. Khalid Hussain whose kind support makes me able to reach at this stage of my life. Word ‘thanks’ is very short in front of his precious support, so this dedication is only showing some respect to him.

At the end I would like to thanks to my supervisor Mr. Faramarz Agahi for his leadership ability, problem solving approach, teaching method and for kind feed backs.

Naveed Hussain
M.Sc Student
I.T University of Göteborg, Sweden
E-Mail: naveedh@ituniv.se

Naveed Hussain

Department of Applied Information Technology

IT University of Göteborg

Göteborg University and Chalmers University of Technology

Abstract

The growth of mobile or unwired usage has increased globally for last few years and there is prediction of continuous grow in coming years. Globalization has made possible for the enterprise to capture different new markets and increase their revenues but this thing also increase competition among enterprises. So in a situation where enterprise could capture whole corporate market while operating at same place, and want to work twenty four hours a day and seven days a week in order to counter competition then the importance of mobile usage in enterprise systems would increase.

This thesis is a step forwards to the growth of mobile usage among enterprise systems and main purpose is to answer, how the design of mobile aware software systems can improves. Based upon news journalism domain requirements two frameworks were selected, analyzed and discussed, in order to investigate important design components of mobile enterprise systems. This effort lead forwards to a new improved framework, called framework for unwired enterprise systems. The proposed framework is designed to answer different important issues arise among mobile enterprise systems like, do it adoptive for future business needs, challenges or changes, is it available on different networks, devices and technologies, is it enough reliable in terms of accurate data and response time, how quickly system acts on user requests, and most importantly, how much the system is secure from misuse or loss of client's data.

Keywords: enterprise systems, mobile usage and service oriented architecture (SOA).

Table of Contents

1. INTRODUCTION.....	7
1.1 PURPOSE	8
1.2 SCOPE	8
1.3 INTENDED AUDIENCE	8
1.4 OUTLINE OF THE REPORT	8
2. THEORETICAL FRAMEWORK	9
2.1 ENTERPRISE SYSTEMS AND MOBILE USAGE	9
2.1.1 <i>What are mobile users?</i>	9
2.1.2 <i>Types of mobile devices</i>	10
2.2 MOBILE ERP ARCHITECTURES	11
2.2.1 <i>Framework for mobile ERP systems</i>	11
2.2.2 <i>Framework for mobile knowledge management</i>	13
2.3 ENTERPRISE SYSTEM VENDORS AND MOBILE ARCHITECTURE.....	14
2.3.1 <i>SAP</i>	15
2.3.2 <i>Oracle</i>	17
2.3.3 <i>SOA, a changing trend in mobile enterprise systems</i>	19
3. METHODOLOGY	22
3.1 RESEARCH APPROACH.....	22
4. DESIGN INVESTIGATION.....	25
4.1 NEWS DOMAIN REQUIREMENTS	25
4.2 DESIGN DISCUSSION	27
5. PROPOSED FRAMEWORK	30
5.1 FRAMEWORK FOR UNWIRED ENTERPRISE SYSTEMS	30
6. DISCUSSION	33
7. SUMMARY AND FUTURE WORK	36
REFERENCES	37

1. Introduction

An enterprise system is a single unified system which integrates all data and processes of an enterprise in order to fulfill their essential business goals. Enterprise system is a set of different modules like supply chain management, customer relationship management, human resource management, data warehouse etc, and all these modules can further be divided into different sub modules, which shows the importance and complexity of enterprise systems in corporate world.

Globalization and competitions in business markets have changed business needs and trends all over the world, which has forced enterprise system vendors to update their enterprise systems continuously and make them adoptive with changing business needs. There are many changing trends in corporate world which are affecting enterprise systems but mobile or unwired usage of enterprise systems is the topic of interest here because enterprises want to capture new global markets for their products or services by operating at one place. Because of these requirements, the mobile workforce in enterprise systems are rapidly growing and their characteristics like flexibility, shorten response time and less operational costs make them more popular among enterprises and clients (*Bär W., et.al, 2005*). The mobile user can access enterprise systems anywhere and at any time through different unwired devices, networks and technologies (*Sobti, et.al, 2002*), and all these things make it possible for the enterprise to be in business twenty four hours a day. Besides all exciting benefits of unwired usage, there are many problems needs to be addressed too, user data is always regarded as the most important factor in traditional enterprise systems and it becomes more critical when it comes from different mobile users at different locations and all needs, accurate data, efficiency and most importantly safety with their records (*Pasi, et.al, 2005*). Mobile clients use different types of mobile devices which use different types of technologies like WAP, HTML etc. and they use different available networks to communicate with the enterprise system (*Cohen D., et.al, 2002*). The system should be available to communicate with almost all types of current mobile devices with their respective technologies and networks and also enough flexible to adopt with new changes (*Kumar S., et.al, 2001*) because mobile clients need clean available interface to communicate with enterprise systems without knowing inside complexity.

The popularity or ratio of mobile usage is directly proportional with client's 'trust' on mobile transaction because while doing mobile transaction on a mobile system the client's mind always feel insecure about their important data for misuse, damage or loose (*Ahonen P, et.al, 2005*). The secure system should create a lot of trust among their mobile clients and their ratio of doing transaction to the system should increase and it also effects the overall growth of system's clients. The enterprise can get more customer satisfaction when its system efficiently response to mobile client's requests with more speed and accurate data (*Park S., Song Y., et.al, 1998*) (*Roth V., 2004*).

1.1 Purpose

In order to produce effective unwire enterprise systems for the corporate world, researchers and enterprise systems vendors put serious efforts on their system's architecture to produce maximum results because "designing or selection of architecture is the most critical factor of overall enterprise systems and inappropriate architecture leads towards higher cost of development, maintenance and efficiency problems" (Dabkowski A., et.al, 2003). So, this study is mainly answering the question of ***how can the designs of mobile aware software systems can be improved.*** The purpose of improved design or framework is to check whether system is secure from misuse or loose, is system available for different mobile devices, technologies and networks, does it provide fast and accurate data, and also do it adoptive for changing business and technology needs.

1.2 Scope

This thesis is a step towards the growth of mobile usage in enterprise systems and investigates all those design components of selected mobile frameworks in order to give clear picture of understanding to mobile enterprises. All these things lead forward to a new improved framework for unwired enterprise systems.

1.3 Intended audience

Mobile enterprises, students and any one, who has interest in enterprise systems and mobile knowledge, are the intended audience of this thesis report.

1.4 Outline of the report

The rest of the report contains following chapters:

Theoretical framework chapter contains an overview of mobile enterprise systems and mobile devices. Two selected frameworks of mobile enterprise systems will be discussed and enterprise system vendors like SAP, Oracle and SOA as a technology will be discussed in order to provide base line of this thesis. *Methodology* chapter contains description of design research approach which was followed to reach the objective of the research. In *design investigation* chapter, based upon news journalism domain requirements the design of two selected frameworks will be investigated and discussed. The *proposed framework* chapter contains a proposed framework for unwired enterprise systems. The *discussion* chapter will evaluate and discuss new framework. At the end *summary and future work* chapter will sum up the whole thesis in few sentences and also indicate future work to be carried out.

2. Theoretical framework

Theoretical framework chapter is divided into three sections. The first section will define enterprise systems and the role or importance of mobile usage in these types of systems.

Second section describes the role or importance of architecture's in mobile enterprise systems and two selected frameworks of mobile enterprise system will be discussed and analyzed. SAP and Oracle as enterprise system vendors and service oriented architecture are discussed in third section.

2.1 Enterprise systems and mobile usage

“The word enterprise can have various connotations. Sometimes this term refers to a large organization with thousands of employees, or very small size with a sole proprietorship, or an intermediate size. So you can define enterprise as a large or medium scale business organization that utilizes computers to solve their business needs. And enterprise system is that software, which helps an enterprise to fulfill their essential business goals“(MedLibrary.org).

Enterprise systems improve the productivity and efficiency of organizations by providing business logic support, which normally contains accounting, production scheduling, bank account maintenance, customer relation, human management and many others. The globalization and competition in current corporate world enforce enterprise to adopt according to current commercial market challenges, and this thing also effects on enterprise system vendors to introduce programmed of steady improvement of both their products and services. (SAP 1972) and (Oracle corp 1977) are two big giants and rivals in current enterprise systems vendor list. Besides these vendors, there are many others open source enterprise systems in market like (Compiere Inc), (GNUe) etc, which also play important role in the development of enterprise systems.

There are many changing trends in corporate world, which are affecting enterprise systems but mobile or unwired is the trend of focus here. Globalization makes it possible for the enterprise to enter into different markets and enterprises want to capture new business markets by sitting at one place, and communicate with their own staff and customers virtually all over the world.

2.1.1 What are mobile users?

It is very hard to define precise mobile users' definition in one or two sentences because this term is being used in a very broad prospective now a days. (Fagrell H., 2000) consider it as “typical situations in which people are mobile and when they are not”, means mobile work is a human activity and people move within the workplace or between workplaces for work, for example postman, traveling salesman, construction worker etc. There are three different state of mobility which is mentioned in following figure (see Figure 1). The *visiting* states shows, the time spend upon one place before

moving to another place (Fagrell H., 2000) e.g. time spend by a salesman while visiting one enterprise. “Wandering is extensive local mobility in a building or local bounded area” (Fagrell H., 2000) e.g. total time spends by a salesman in one enterprise building to meet different clients, Where as “traveling is the process of going from one place to another in a vehicle (Fagrell H., 2000)” e.g. a salesman travel from one client’s organization to another.

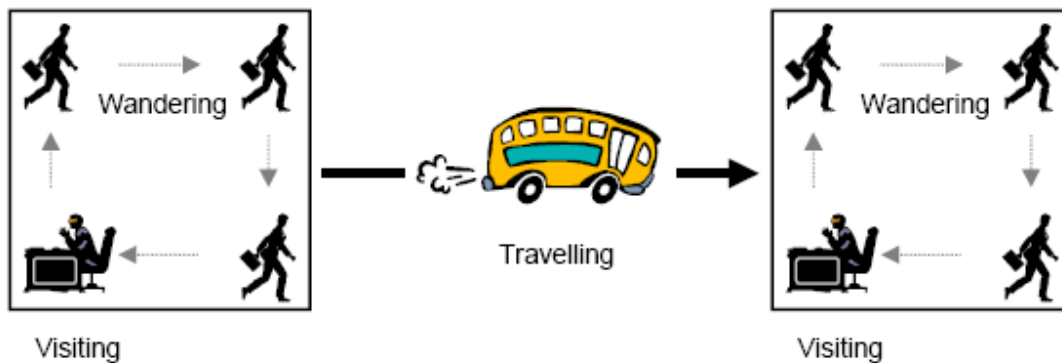

Figure 1: a mobile user scenario (Fagrell H., 2000).

These types of activities are quite common in our surroundings that are why, mobile usage shows rapid growth trend in our modern society and the sales of different mobile devices is growing very vastly. This growing trend enforces mobile vendors to produce new applications and businesses that exploit mobile usage technologies in different ways. Today, mobile usage has become vast field and different researchers are working on, how to create new mobile applications or to enhance existing mobile applications for example e-commerce systems, database, search engine and web browsers. And they also are working on, how mobile user data could discover and how we could evaluate their performance. All above mentioned research shows the importance of unwired usage in current corporate world’s enterprise systems

2.1.2 Types of mobile devices

“Any device which could access information any time and anywhere is called mobile device (Cohen D., et.al, 2002)”. Some examples of mobile devices are; *Information appliance, Smartphone, Personal digital assistant, Mobile phone, Personal Communicator, Handheld game console, Ultra-Mobile PC, Handheld television* etc. There are many others feasible and popular technologies are working in the global market but it could predict that mobile devices remain dominant in coming years.

Mobile vendors have to consider different network capabilities that need to be considered because of possible technical, ergonomic or economic implications for a mobile user include: *bandwidth, battery, capabilities, cost, input, memory, processing power, screen, text, voice, usability, connectivity* and many others.

2.2 Mobile ERP architectures

“Designing or selection of architecture is the most critical factor of overall enterprise systems because inappropriate architecture leads towards higher cost of development, maintenance and efficiency problems” (Dabkowski A., et.al, 2003). etc. Different researchers have designed and implemented mobile enterprise architectures successfully in real case studies and some researchers are still working on mobile architectures to enhance its functionality and to meet future or upcoming business challenges. For this particular study, the author has chosen two frameworks for mobile enterprise systems in order to compare and discuss their architecture functionality and characteristics. The first framework is directly related with this study and described in *section 2.2.1*. The second framework addressing ‘mobile knowledge management’ and does not have direct link with enterprise systems but mobile or unwired involvement made it attractive for this study and is described in *section 2.2.2*.

2.2.1 Framework for mobile ERP systems

(Dabkowski A., et.al, 2003) has designed a framework for mobile ERP systems. This architecture is inspired by tier concepts, mostly with three tiers concept in which, *presentation layer* provides clean interface to users, *business layer* deals with enterprise business logics and *database layer* manipulate user data. The framework contains following four tiers (*see* Figure 2):

- **ERP system’s database:** tier acts as a database layer and provides all data manipulation facility to mobile users.
- **Business logic:** tier is the second layer of this framework and responsible for the business logics of mobilization process. This tier contains:
 - *Content access engine:* deals with mobile device characteristics and build queries for ERP data according to mobile user requests, and also transforms the retrieved data into XML format.
 - *Cache storage:* used for temporary storage of XML files, containing mobile user’s data.
 - *Remote function call (RFC) server:* is used to invoke business functions of an ERP system in a remote way. Whenever mobile user needs to modify, update, or wants to interact with ERP database, their requests reaches to RFC server and RFC server then invokes responsible functions for respective tasks.
- **Content extraction engine:** is the third layer of this framework and acts as not only presentation logic layer but also deals with graphical user interface (GUI) of mobile devices. This tier determines the type of browser and identifies the most important device characteristics, besides all, it also handles the content specific displaying capabilities of mobile devices.

- **User interface:** is the fourth and last tier of this framework and encompasses different mobile devices like laptop, PDA, WAP enabled phone etc. with their respective browsers and GUI.

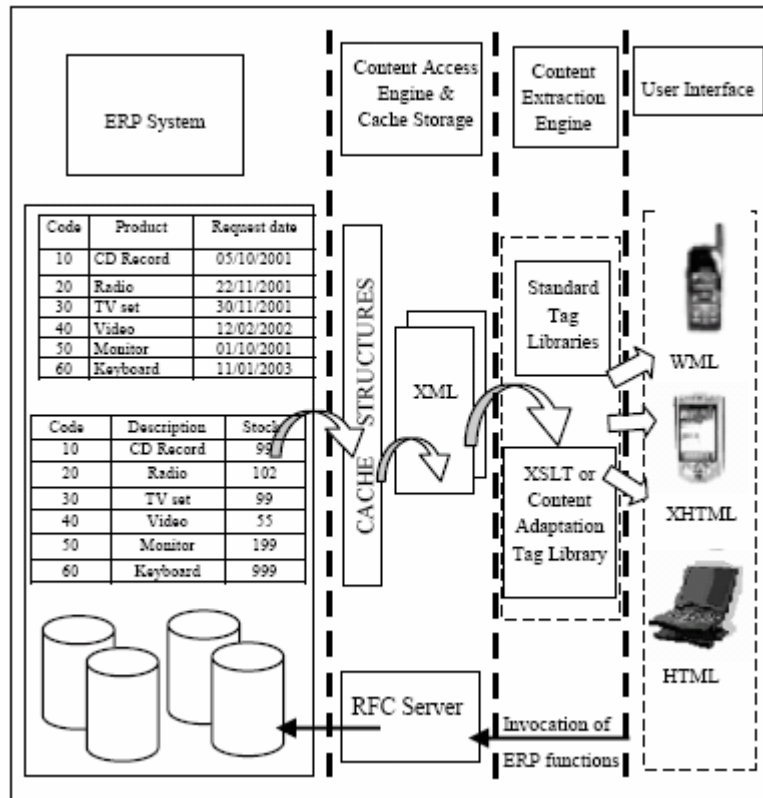

Figure 2: (Dabkowski A., et.al, 2003) framework for mobile ERP.

(Dabkowski A., et.al, 2003) predicts continuous growth of mobile usage in coming years and suggests “the mobile ERP architectures should be based upon innovative web services architectures” because web services provide unique solutions in the process of inter-enterprise cooperation and integration of different types of devices. (Dabkowski A., et.al, 2003) is working on the implementation of effective web-service based architecture for mobile ERP systems, but a practical implementation of this framework is still not available.

2.2.2 Framework for mobile knowledge management

To address the issue of ‘data or knowledge management’ and ‘mobility’, (Fagrell H., 2000) proposed a framework called ‘mobile knowledge management’ by merging together knowledge management and mobility. The purpose of this framework was to produce timely knowledge for mobile users in such a way that knowledge should be relevant for the task in hand by mobile user. By keeping news journalism domain requirements, this framework had passed through six different stages and come up with architecture, called FieldWise (Fagrell H., 2000) and the six stages are described as follow (see Figure 3):

- The framework starts with two concurrent activities to explore the possibilities of new IT usage.
 - An empirical study, and
 - Experiments with technology
- Based upon technological ideas and empirical findings, a design proposal is formulated which leads towards the development of a prototype.
- To get users feedback on its design qualities, the prototype is implemented into three different real work conditions.
- The generalized ideas to use other mobile domains were used to design a final mobile architecture i.e. FieldWise.

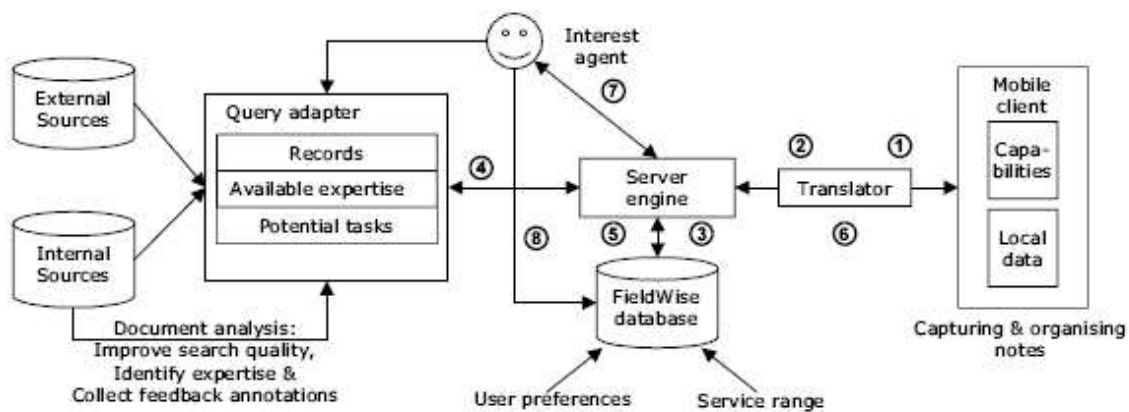

Figure 3: FieldWise (Fagrell H., 2000), mobile knowledge management architecture.

Following listing explain FieldWise’s internal communication and functionality, same as (Fagrell H., 2000).

1. The mobile client connects and the user’s notes are sent to the server engine.
2. The server engine analyses the capabilities of the client and selects the appropriate translator to adapt its response.
3. The server engine creates an interest profile based on the notes and stores it in the FieldWise database.
4. The interest profile is sent to the query adapter, which performs a search in internal and external sources. The server engine receives the results.

5. The server engine looks in the FieldWise database for overlaps with the interest profiles of other co-workers. If there is an overlap, the server engine notifies the co-workers. The response to the user is also adapted according to the user's preferences stored in the FieldWise database.
6. The results are translated and returned to the mobile client, which presents and stores the results locally.
7. The server engine configures the interest agent to continuously monitor for updates that match the user's interest profile.
8. If the interest agent identifies an update, the FieldWise database is modified and the user is notified.

FieldWise architecture has been implemented in newspaper domain together with editorial system called Impress, which used in Swedish newspaper (*Fagrell H., 2000*). (*Oracle 1977*) was used as a joint database manager for both FieldWise and IMpress system and the news server was implemented in Java on the Microsoft windows 2000 platform, and also the electronic calendar of Microsoft Exchange server was used to find out the availability of people. The communication between client and system was done by TCP/IP protocol at server side, and GSM (Global System for Mobile) and PPP (Point to Point Protocol) used at client side in order to establish wireless communication channel. The internal structure of FieldWise is encoded in XML (eXtensible Mark-up Language) which supports XMLNews (*Fagrell H., 2000*), as preferable internal query language of news domain. All above mentioned technologies and searching feature of FieldWise, makes it popular in news domain.

FiledWise architecture is best suited for news journalism, sales and real estate brokering domains (*Fagrell H., 2000*). But it can also be adopted by organizations where people are distributed or mobile, tasks are time critical and have to meet necessary deadlines, end result interrelate with people tasks and knowledge sharing among people got high priority (*Fagrell H., 2000*).

2.3 Enterprise system vendors and mobile architecture

The growth of mobile usage in normal life and its effects on corporate world also affect enterprise system vendors to think on this issue and come up with feasible solutions. Competition among enterprise system vendors also helps them to enhance their systems' efficiency and make it adoptive according to current market needs.

(*SAP, 1972*) and (*Oracle corp, 1977*) are continuously attracting enterprises globally by different exciting and interesting features of their enterprise systems. *Section 2.3.1 (SAP, 1972)* and *section 2.3.2 (Oracle corp, 1977)* will explain both enterprise system vendors journey from simple ERP system to mobile enterprise systems, respectively. Besides these vendors there are some other open source ERP systems vendors like (*Compiere Inc*), (*GNUe*) etc, which are also capturing enterprise market share. These technologies also considered for this study but their efforts regarding mobile usage are still abstract and needs more time to mature, that's why they have been neglected here. At the end,

Service Oriented Architecture (SOA) will be explained in *section 2.3.3* as a changing force or trend in mobile enterprise systems implementation.

2.3.1 SAP

Systems, Applications and Products (SAP, 1972) in data processing were founded by five former IBM engineers in Mannheim, Germany. (*SAP, 1972*) has now become the largest software company in Europe and the third largest in the world after Microsoft and IBM in terms of market capitalization (*Wikipedia*). SAP biggest achievement in terms of revenue is to provide Enterprise Resource Planning (ERP) solution to enterprises, and remembered as a pioneer of ERP systems (*Wikipedia*).

In today's highly competitive business environment, enterprises are faced with the challenge of balancing cost and revenue, while maintaining or improving customer service and quality levels, and needs to do business anywhere and at any time, has enabled business collaborations to take place. The revolution of IT technologies in hardware and software put business into electronic by making an 'electronic community' of manufactures, distributors and customers, which can perform business transactions among each other in electronic marketplace portals (*SAP white paper, 2005*). To address all above mentioned problems and to adopt it according to current and future challenges, (*SAP, 1972*) introduces mySAP.com and four main SAP internet strategy elements, which are (*SAP white paper, 2005*):

- mySAP.com Marketplace
- mySAP.com Workplace
- mySAP.com Business Applications
- mySAP.com Application Hosting

The journey of (*SAP, 1972*) architecture starts with two-tier central systems; SAP R/1 and R/2 systems are the examples of two-tier architecture (*SAP white paper, 2005*). Then client/server concept forced SAP to migrate from two-tier architecture to three-tier architecture (*SAP white paper, 2005*), during R/3 development. In three-tier architecture every layer has distinct function, the *presentation tier* provides clean interface to the user, the *business tier* deals with all business logic and the *database tier* is used to store and retrieve business data. But the rapid change of business needs, competition, globalization and technology advancement forced (*SAP, 1972*) to think again on their systems architecture and come up with new solution for new needs. So that, mySAP.com architecture introduced with one new tier called 'internet middleware' (*SAP white paper, 2005*) and became multi tier (*see Figure 4*).

Traditionally *presentation tier* installed on a PC and provides the SAP Graphical User Interface (SAP-GUI), but now, this interface can be available through a web browser and additional *Internet middleware tier* transforms the SAP-GUI protocol into HTTP via TCP/IP access, which consumes very little network bandwidth (*SAP white paper, 2005*).

To increase flexibility and business efficiency in their architectures, and also want to use the benefits of Service Oriented Architecture (SOA), (*SAP, 1972*) has been defined "an

open architecture for adaptive business solutions”, called SAP Enterprise Services Architecture (ESA), which has enabled on SAP Net Weaver platform using web services (Perry R., et.al., 2005). ESA is based upon five key principles, which are (SAP white paper, 2005):

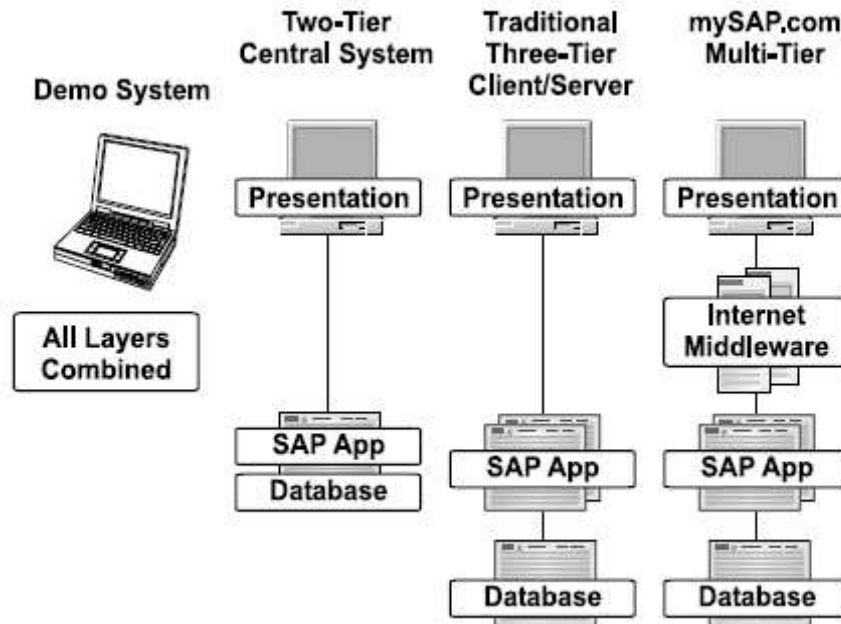

Figure 4: (SAP white paper, 2005) the multiple software tiers of SAP systems.

- **Abstraction:** means a clean interface by hiding all those technical details that can be confused for end users.
- **Modularity:** means the breakage of complex tasks into different reusable tasks.
- **Standardized connectivity:** means the composition of services to form standard processes.
- **Loose coupling:** means the evolution of various components without any effect of integration.
- **Incremental design:** means continuous changes of components without effecting internally.

mySAP.com also supports ‘SAP mobile infrastructure’, which enables the extension of mySAP.com business suit solutions to mobile devices in either connected or disconnected environment. (SAP, 1972) mobile infrastructure is based upon open standards like Java, extensible markup language (XML) and simple object access protocol (SOAP). This open architecture of SAP mobile infrastructure offers true device and network independence, and able to support almost every type of handheld device (SAP white paper, 2005). The (SAP, 1972) mobile infrastructure client is installed on mobile device, which includes its own web server, business logic and application layer, the synchronization and replication layers, provides support for the field-based applications beyond the application walls (SAP white paper, 2005).

(SAP, 1972) has designed with many other technologies which physically push (SAP, 1972) applications to a mobile a device (SAP white paper, 2005). For example SAP console, Web SAP console and Web Dynpro. All these mobile applications create the secure encrypted environment, and ensure enterprise that their business data is safe, whether it is utilized in the confines of enterprise building or beyond its walls.

2.3.2 Oracle

(Oracle corp, 1977) is one of the leading IT companies with more than 145 offices in different countries around the world. (Oracle corp, 1977) has bought many enterprise systems vendor companies like (PeopleSoft), (J.D.Edwards) and (Sieble) systems, and with the help of these companies (Oracle corp, 1977) is developing ERP software's, Customer relationship management (CRM) software's and Supply chain management (SCM) software's, this thing makes (Oracle corp, 1977) the biggest rival of (SAP, 1972) in terms of enterprise management systems. Besides enterprise software's, (Oracle corp, 1977) is also developing database management systems, tools for database development and middle-tier software like Fusion middleware (Oracle white paper, 2005).

(Oracle corp, 1977) has developed a complete business suite for enterprises called 'E-business suite', which is a collection of ERP applications, with core RDBMS database as back end. (Oracle corp, 1977) latest e-business suit contains several product lines such as oracle financials, oracle logistics, oracle HR, oracle sales and many others (Oracle white paper, 2005), all these products contain different complex modules and sub modules.

(Oracle corp, 1977) can not isolate itself from mobile usage revolution in industry and have developed a suit for enterprises to resolve mobile or collaboration problems, called 'oracle collaboration suit' (Oracle white paper, 2005), which integrates messaging, calendaring, file sharing, real time communications, time management, voice mail and fax services on an enterprise class infrastructure. As a part of oracle 10g technology (Oracle corp, 1977) mobile collaboration provides every possible channel to access all collaboration information, making the dream of universal access really come true. With the help of this technology, users do not need to have multiple mobile devices to access different collaboration applications, and it could access from the device of their own choice (see Figure 5). Oracle mobile collaboration suit contains following features (Oracle white paper, 2005):

Mobile push mail is the main feature of (Oracle corp, 1977) mobile collaboration and (Oracle corp, 1977) is making efforts for the standardization of mobile email based on open (P-IMAP) standards with the help of IETF and Open Mobile Alliance (OMA) because there are many mobile email solutions available in the market, with the support of limited mobile devices and one enterprise can not support all mobile networks or technologies at all time. So, *Mobile push mail* is based upon open standards and support multiple networks, file attachment, folder, filter support, and also provide secure real time access to systems (Oracle white paper, 2005).

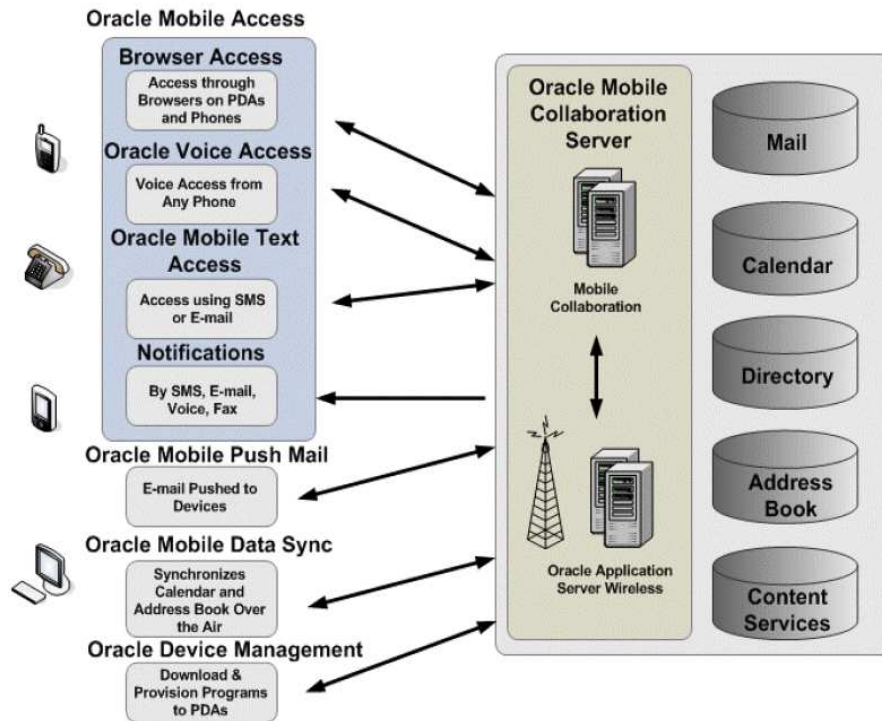

Figure 5: (Oracle white paper, 2005) Oracle mobile collaboration suit.

Mobile data sync is the second feature of (Oracle corp, 1977) mobile collaboration and provides the server piece of standard-based synchronization infrastructure. With the help of this feature user can use any type of internet connection methods like GPRS, infrared, Bluetooth etc (Oracle white paper, 2005), because (Oracle corp, 1977) *mobile data sync* is not tied with any particular internet connection model (Oracle white paper, 2005).

Mobile access feature deals with ‘how to reach mobile user’, there are three types of mobile access (Oracle white paper, 2005):

- *Mobile browser access* provides access to collaboration information from any mobile device with browser capabilities, and there is not any restriction of particular type of browser.
- *Mobile voice access* provides the most ubiquitous access channel that is ‘voice’ because voice communication remains the most important communication method within human. Setting up an automated conference call using enterprise directory information is the most important sub feature of *mobile voice access* (Oracle white paper, 2005).
- *Mobile text access* allows users to access collaboration suit via following text features:
 - *Mobile email*
 - *Mobile inbox*
 - *Mobile calendar*
 - *Mobile files*
 - *Mobile personal address book*

Mobile device management is designed for administration in order to configure and control the behavior of the corporate fleet of mobile devices. *Mobile notification and availability management* provide some extra features to collaboration suit (*Oracle white paper, 2005*).

2.3.3 SOA, a changing trend in mobile enterprise systems

(*Zhang T., et.al, 2006*) “Service oriented architecture is a design framework for construction of information systems by combination of services”

As evident from the above definition, SOA is not linked to a specific technology, rather than it can be implemented using a wide range of technologies such as EJBs, DCOM, strus framework, RPCc or web services (*Komoda N., 2006*). It is regarded as a method of information systems that justifies the creation of applications, formed by the combination of loosely coupled and interoperable services (*Zhang T., et.al, 2006*). Moreover practically speaking, SOA means different things to different people, if we consider this with respect to an IT architect, it means the overall enterprise architecture, definition and the process that enables IT to develop and deploy business case rapidly. For LOB-IT liaisons, it means the governance, organizations and process for project/program management, and various business building blocks that could potentially be reused in order to reduce cost. Apart from this, SOA is a potential liability for legal team, and an IT strategy for delivering business capability for the CIO of the company (*Stal M., 2006*).

The main purpose of SOA is a world wide mesh of collaborating services, which are published and invoked on the service bus. In other words, we can say that SOA is not just architecture of services from the technology perspective, but the policies, practices and frameworks by which it becomes easy to ensure that right services are produced and consumed (*Perry R., et.al, 2005*). One needs to give importance to certain guiding principles, if he wants to design or use a particular SOA. These guiding principles should be granular, modular, compos able, componentized and interoperable. In additions to its guiding principles, there is also a whole bunch of architectural principles for design and service definition. Some of the architectural principles of SOA are: encapsulation, loose coupling, contract, abstraction, reusability, compos ability, autonomy, seamlessness and discoverability.

The main objective of the above mentioned guiding and architectural principles of the service-oriented approach are to reduce dependency between individual ‘software islands’, which comprise services and clients accessing those services. Hence in order to achieve it, these service-oriented distributed software systems need to cooperate via a common communication protocol. Moreover, these distributed software entities, exists in heterogeneous environments, so that client developers can not control remote services implementation details. Apart from this, the distributed software systems most of the time, comprise of highly dynamic environments, and as a result of this, the designer can not statically predefine many decisions, and hence they need to be configured dynamically.

2.3.3.1 Web Services and Service Oriented Architecture

If any service oriented architecture needs to be effective, then one should have the clear understanding of the term service. A service is a function that is well-defined, self-contained, and does not depend on the context of state of other services. Services are what we connect together using web services. A service is typically the end point of a connection. Hence, the technology of web services is the most likely connection technology of service-oriented architectures. Web services essentially use XML to create a robust connection.

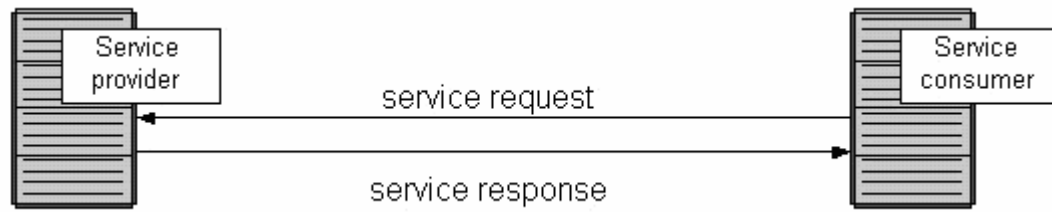

Figure 6: (Alonso G., et.al, 2005) web services communication in SOA.

Moreover, web services are a new breed of web applications. They are self-contained, self-describing, modular applications that can be published, located and invoked across the web. Web services perform functions, which can be any thing from simple requests to completed business processes. Once a web service is deployed, other applications (and other web services) can discover and invoke the deployed web service.

2.3.3.2 Role of Service-Oriented Architecture in mobile ERP Systems

Nowadays, business environment rapidly changes, and as a result the life cycle of business and product also changes. As it is evident of the fact that life cycle of business and products become short and mobile, the demand for the sort of architecture which is mobile, modular, scalable and interoperable started increasing. The main advantages of using SOA in industrial systems are that the later one can be easily modified by replacement of services. Also, the rapid and low cost of system development by combination of services is realized (Komoda N., 2006).

In today's world, it is the need of the hour that mobile systems should be adaptive to various changes in different business models. Moreover, the business people wants to have their IT solutions ready rapidly, and at a very low cost so that they would be able to start implementing their business plans without wasting any time. Apart from the adaptability and low cost, one important thing is that the mobile systems should be of enhanced quality. Because it is evident of the fact that poor quality leads to the severe drawbacks on business such as customer dissatisfaction and opportunity loss. Lastly, the most important factor is the reduction of maintenance costs, which is also indirectly linked with total quality management of Information Systems.

One of the main advantages of using SOA in industrial mobile ERP systems can be modified easily by simply different services. This approach is similar to component based

software engineering, where components can easily be plugged in or out of the system for its maintenance. Second main advantage is that two or more services can be combined together to perform a specific function. This results in the rapid development of a system, thus keeping its cost low. The third main advantage is that total quality management of the information system can be enhanced if we avoid re-inventing the wheel, or in other words valid or proven services are used instead of the new one. By enhancing the total quality management, maintenance cost will be drastically reduced (*Komoda N., 2006*).

3. Methodology

Design research is the methodology of this thesis because the purpose of this research is to investigate all those design components of mobile aware software systems which influenced the overall productivity of the system and based upon these design components, to propose a new improved framework for unwired enterprise systems in order to get better results as compared with previous frameworks.

The phases of design research are elaborated below indicating awareness of problem, suggestion, development, evaluation and conclusion as *process steps (ISWorld)* with their respective outputs. These *process steps* are described as follow:

Awareness of problem: ‘why we need the solution of a problem’ could be the starting point of a research and the *need* can come from multiple resources like new developments in related discipline, dissatisfaction on previous research etc. The formal or informal proposal of a new research comes as outputs of this phase (*ISWorld*).

Suggestion: The suggestion phase is intimately connected with awareness of problem phase and contains suggestions for a problem solution made from available knowledge. Tentative design is the output of this phase which is presented along with proposal, indicating by dotted lines in the figure (*ISWorld*).

Development: According to (*ISWorld*) “The Tentative Design is implemented in this phase. The techniques for implementation will of course vary depending on the artifact to be constructed”

Evaluation: After development phase when design has successfully constructed, the artifact is evaluated with the help of criteria available at proposal. “Deviations from expectations, both quantitative and qualitative are carefully noted and must be tentatively explained” (*ISWorld*).

Conclusion: is the final phase of design research and “Typically, it is the result of satisfying, that is, though there are still deviations in the behavior of the artifact from the (multiply) revised hypothetical predictions, the results are adjudged “good enough.” Not only are the results of the effort consolidated and “written up” at this phase, but the knowledge gained in the effort is frequently categorized as either “firm” - facts that have been learned and can be repeat ably applied or behavior that can be repeat ably invoked - or as “loose ends” – anomalous behavior that defies explanation and may well serve as the subject of further research” (*ISWorld*).

3.1 Research approach

The following figure show a tailored version of the generic design research approach which will be used in order to carry out this research.

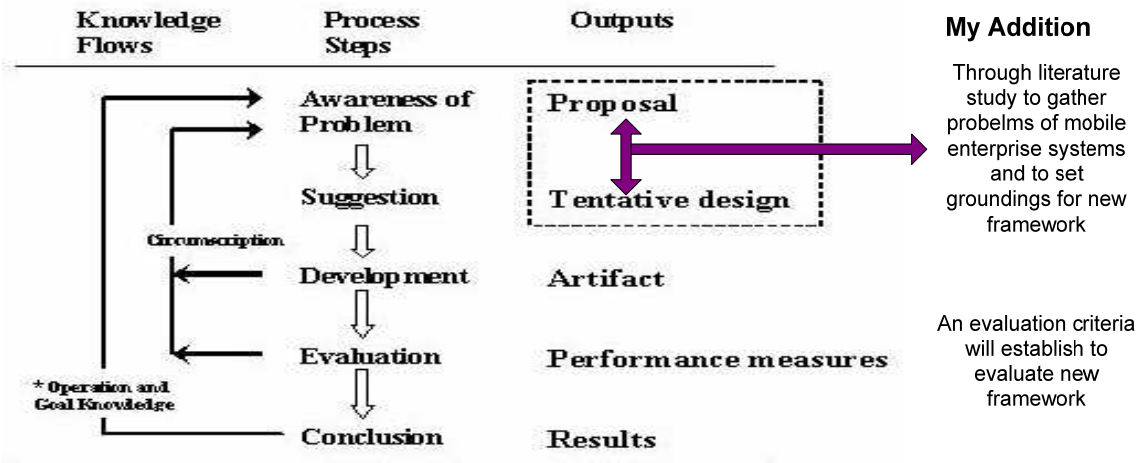

Figure 7: (ISWorld), the customized version of generic approach of design approach

A literature study will be conducted in order to investigate all those design components of mobile aware software systems which influenced the overall productivity of the system. This literature study covers the role or importance of mobile usage in enterprise systems, why enterprises want to migrate or update their enterprise systems into unwired enterprise systems, what are the contributions of enterprise system vendors in the development of mobile enterprise systems, how are researchers dealing with this issue, why researchers emphasize on the design of mobile frameworks, how the design of framework effects the overall productivity of the enterprise system and how service oriented architecture will help to implement frameworks for mobile enterprise.

In order to investigate important design components of mobile frameworks, two frameworks have been selected and further investigated and discussed into news journalism domain requirements. News domain requirements will be used as secondary source of data investigation where secondary sources (Myers M.D., 1997) refer to any materials like books, articles, tutorials about certain tools etc. which have been previously published. This effort leads forward to propose a new improved framework for mobile enterprise.

To evaluate new framework, an evaluation criteria is designed and described in table (see Table 1). Based upon this criterion the new framework will be evaluated and discussed in order to support design decisions.

Name	Description
Availability	What is the probability that the system is operating at specific time?
Security	How data could safe from misuse and loose?
Reliability	How much the ability of a system to perform its required functions under stated conditions for a specified period of time?
Performance	How quickly system responses to user requests?
Adoptability	Is system enough flexible to adopt with changes?

Table 1: the evaluation criteria

There is not any platform available for the author to evaluate proposed framework with respect to evaluated items mentioned in above table (*see* Table 1). So, literature study of evaluated items *i.e. availability, security, reliability, performance and adoptability*, is the source of investigating selecting and proposed framework for mobile enterprise.

IEEE, Related books, Chalmers and Göteborg digital libraries and Google search engine are main sources of knowledge used for this study.

4. Design investigation

In this chapter, the news journalism domain requirements will elaborate in *section 4.1* and based upon these requirements the design of two selected frameworks will discuss in *section 4.2*.

4.1 News domain requirements

To investigate the real work flow or processes of mobile knowledge management, an empirical research was conducted in September 1998 at public service radio station in Gothenburg, Sweden (*Fagrell H., 2000*). The radio station is still popular among Swedish people and is being broadcasted nationally and in the local region. The station is broadcasting many attractive programs but this study is restricted to investigate only two programs, which are:

- *News update*: program, in which news are broadcasted or updated after every hour.
- *Gothenburg direct*: program contains interviews, music, and discussion and also covers what new will happen in the local region.

All above mentioned two programs were running separately at station with their own dedicated staff members but the ‘news collection’ activity is common or shared among these three programs. The view of radio station office is similar like any other normal news organization with a large table at center where journalists join together for daily formal or informal meetings. All indoor journalists at station have PC’s and stationary phones at their work desks with printer and internet access via centralized local area network. The field journalists of the station are equipped with mobile phones and also a microphone that is connected to a transceiver on a rucksack. When an event or news comes to the field journalist, he/she use his equipment to broadcast to a van where the signals are amplified and sent to the radio station. To keep track of old and upcoming events, news station usually used a document management system called MANUS which normally contains telegrams, broadcast reports, program manuscripts and paper based diary containing journalist’s important information (*Fagrell H., 2000*).

Every day there is a scheduled meeting in radio station at 8.30 am that is lead by the editor of the news update. Journalists from all local programs gather at a large table in the middle of the office. Based upon MANUS, the editor assigns roles and responsibilities to each journalist aiming ‘what should be done today’, and journalists can share their roles and problems with editor and co-journalist in order to get clear picture of today’s work. This general meeting normally continues for almost half an hour and at the end of meeting everyone has an overview of the preliminary schedule of the day. Besides this general meeting, the two selected programs usually have separate short meetings where the discussion from the morning meeting continuous. A news item program contains following three types of format (*Fagrell H., 2000*):

- *Recorded interviews:* are those interviews which are recorded by telephone or through a field interview, and can be edited before broadcasting.
- *Live interviews:* Is non-editable broadcasting and can be done in the studio, in the field, or on the telephone.
- *Talkers:* are either recordings or can be read live by journalists and can always be found as part of the program.

Every news item type has advantages and limitations. For example, in case of recorded interviews, it is always possible to edit it, in order to make it better understandable. But some time the receiving material is so insufficient that could not fulfill recording objectives and the time spend on material collection feel like effortless and even last minute editing could not make it possible to deliver. Same in the case with live interviews, in which journalists can ask maximum numbers of appropriate questions in his time frame, but the possibilities to change the focus, is limited and it is hard to modify live interviews later. To overcome these types of problems editor or program responsible usually rearranges the parts of the program and use some back up materials e.g. advertisement break etc (Fagrell H., 2000).

The process of data management between field reporters and indoor journalists is very interesting and challenging. In news domain this process involves *exploring* and *elaborating* as two main sub processes. The *exploring* process is used to investigate potential news items and initiate them, and the *elaborating* process is used to research on initiated news to produce reportable news items. Both these sub processes are used as knowledge intensive processes and some times together used in co-operative ways (Fagrell H., 2000).

In order to fulfill *exploring* and *elaborating* tasks journalists have to taking care different important considerations in the process of potential news items. For example, in the case of *exploring* news items journalists have to consider following questions like (Fagrell H., 2000), *what have others done?* By answering their competitors' efforts on this news item, *what have we done?* By keeping in mind their previous efforts on this news; *is it unique in the repertoire?* By giving equal attention to all affected parties, *is it valid?* By confirming the source of news and validity, and *is it possible to do?* By adopting the right procedure for right news (Fagrell H., 2000).

During *elaborating* task journalists have to keep in mind following questions which are: *what have others done?* Including competitors and any third party efforts, *what have we done?* By keeping in mind our previous efforts on this news; *are there any new issues to discuss?* *How does it relate to the repertoire of the channel?* And *what is possible to do?* are some important considerations in the process of *elaborating* news (Fagrell H., 2000).

Time is the most important factor of this domain and needs 'timely information' between distributed field and indoor journalists. That's why they can not relay on traditional desktop based systems, and need handheld devices for mobile communication. (Fagrell H., 2000) In short, this domain could divide into following main requirements to fulfill:

Support evolving tasks ad notify users of interdependencies address the issue that journalists take ‘notes’ to remember and reduce the complexity of their tasks. It demanding a system that should support the user’s tasks, as they evolve and it should also notify the users of interdependencies between tasks, and provide access to tasks that are potentially interesting.

Overview of records shows similarities or matching of records with previous records, in order to give an idea to journalists that, what have been done on this issue previously (Fagrell H., 2000).

Suggest of available expertise deals with references of different experts with their respective area or tasks, in order to give a facility to mobile user to contact with right person with right accessible channel in short spam of time. *Filter information* required by mobile users to fulfill their short-term and long term tasks. The criteria of filtering information are depending upon tasks nature and importance, and could change during time. *Dynamic configuration of mobile services* is necessary to support according to current user preferences and mobile device capabilities (Fagrell H., 2000).

All above mentioned news domain problems are demanding one mobile enterprise system which can solve their all business needs without affecting their current status and give them an edge above their competitors in terms of accuracy, safety and most importantly with speed.

4.2 Design discussion

It is very hard to explain which one is the most suited framework for news journalism domain as both selected frameworks could produce almost same results (Dabkowski A., et.al, 2003) (Fagrell H., 2000). Perhaps other types of mobile enterprises will also not take interest on this answer because mobile work varies from enterprise to enterprise and business needs can change during time. So based upon news journalism requirements author will discuss all those design components of selected frameworks which help to satisfies journalism domain needs and can lead forward to a new improved framework. Similarities and difference between selected frameworks are described as follow (see Figure 8):

- *User interface* and *mobile client* components encompasses different mobile devices like laptop, PDA etc with their respective browsers, GUI and storage capability.
- Both *content extraction engine* and *translator* components deals with dynamic configuration of mobile devices. Each handheld device has unique feature, technology, GUI, web browser and capabilities, and also network capacity should determine data efficiency or response measure. Both these components identifies mobile device characteristic in order to establish a reliable communication channel (Dabkowski A., et.al, 2003) (Fagrell H., 2000).

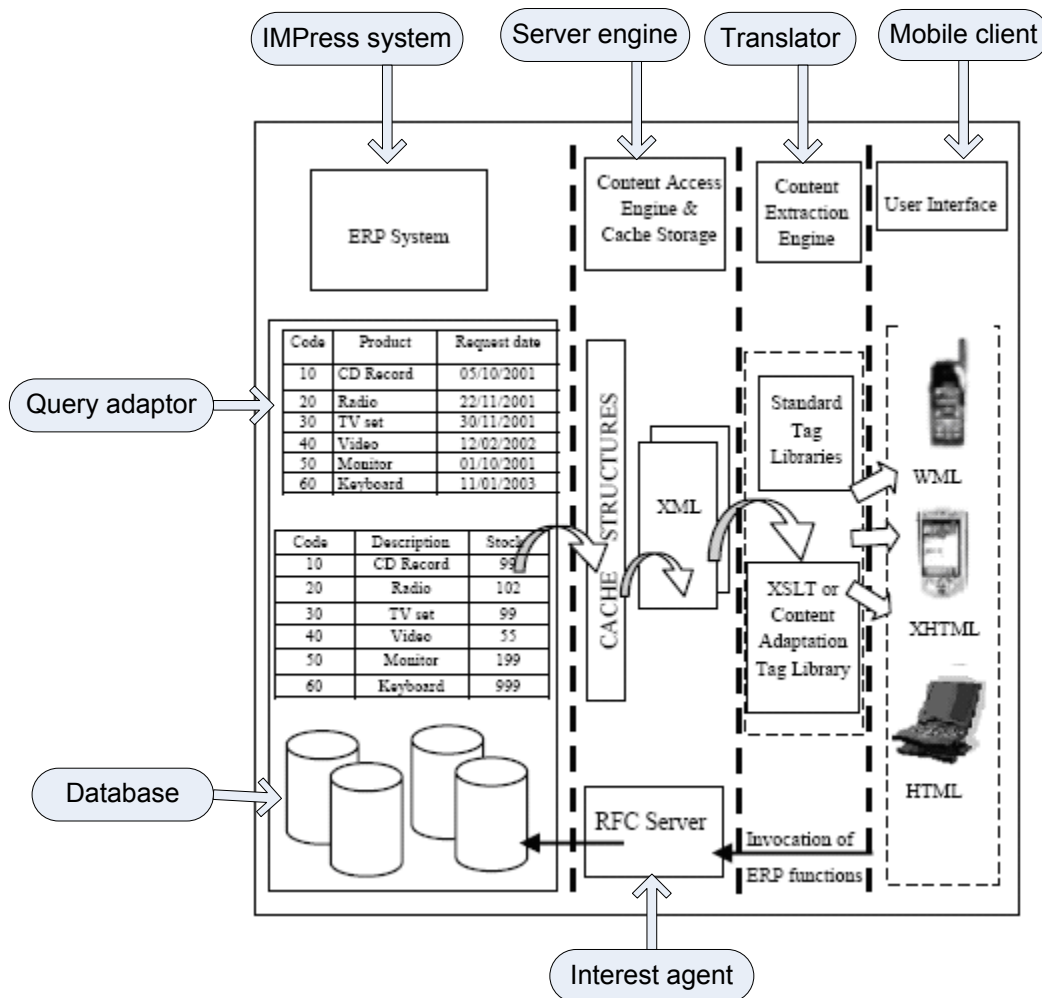

Figure 8: (Dabkowski A., et.al, 2003) Vs (Fagrell H., 2000).

- *Content access engine* and *server engine* components deals with business logic of news or any other enterprise. After establishing successful communication channel both these components help to build quires for enterprise data according to mobile user requests, and also transform the retrieved data into XML format i.e. XMLNews format in case of news journalism domain (Dabkowski A., et.al, 2003) (Fagrell H., 2000).
- (Dabkowski A., et.al, 2003) and (Fagrell H., 2000).use third party Relational Database Management System (RDBMS) as data storage i.e. oracle as RDBMS used in news journalism domain
- *Remote Function Call (RFC)* and *interest agent* components are used to invoke business functions of enterprise systems in a remote way. Whenever mobile user needs to modify or update enterprise data their requests reached to these components and then they invoke responsible functions for respective tasks (Dabkowski A., et.al, 2003) (Fagrell H., 2000).

- Based upon mobile user interests, the *query adaptor* performs a search in internal and external sources, and results send back to *RFC* or *interest agent*.
- (*Dabkowski A., et.al, 2003*) and (*Fagrell H., 2000*) frameworks can adapt with any other system i.e. IMPress system in news journalism domain, because the structure of both frameworks is enough flexible to work with other systems.

The (*Fagrell H., 2000*) *framework for mobile knowledge management* is purely designed to support news journalist domain requirements which can also fit in other domains like sales or similar types while (*Dabkowski A., et.al, 2003*) *framework for mobile enterprise system* is designed to support any enterprise which supports mobile work. Followings are some differences between two frameworks:

- (*Dabkowski A., et.al, 2003*) framework is divided into four logical layers and mobile enterprise systems is provided by different vendors like (*SAP 1972*) and (*Oracle corp 1977*) are also represent in four logical layers. These logical layers give clean overview of each layer, functionality and their respective work. While (*Fagrell H., 2000*) framework does not represent their components in the form of logical layers.
- (*Fagrell H., 2000*) framework supports simple libraries to display information on journalists' mobile device while (*Dabkowski A., et.al, 2003*) framework give freedom to display simple information to mobile users by using standard tag libraries or display information in a fancy style by using eXtensible Stylesheet Language Transformations (XSTL) libraries.
- The (*Dabkowski A., et.al, 2003*) framework give *cache structure* as a sub component of *content access engine* which stores information ('profile' in the case of news journalist domain) inside at the time of query execution, and later if mobile user need that information again, the framework will fetch that information from cache and deliver it to the user instead of executing same query again. This thing reduces processing time, protect data duplication and increase the overall performance of the system.

5. Proposed framework

Based upon design investigation and discussion of two selected frameworks (see *chapter 4*) a new improved framework for unwired enterprise systems is presenting in below section.

5.1 Framework for unwired enterprise systems

The general architecture developed for unwired enterprise systems is outlined in below figure (see Figure 9). The framework for unwired enterprise system is divided into four logical tiers and each tier is responsible of certain well defines procedure and functions which is explained as follows:

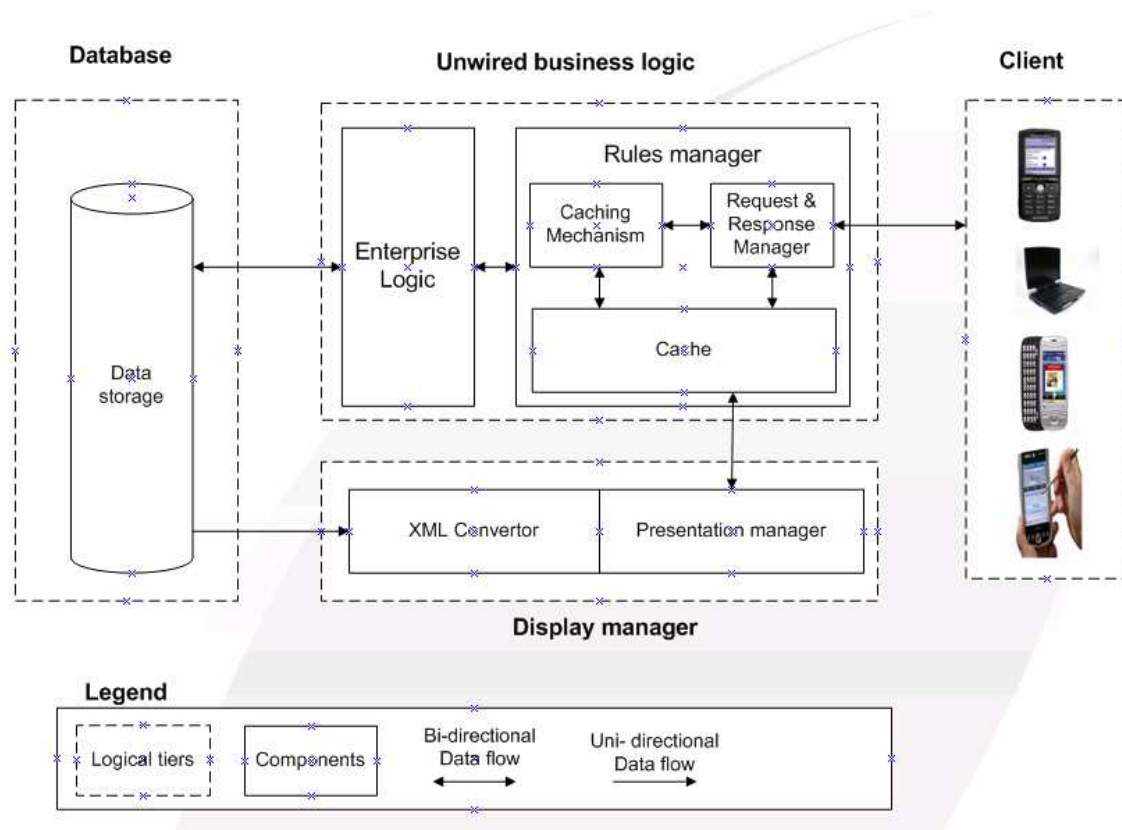

Figure 9: proposed framework for unwired enterprise system

Client tier: is designed by keeping an idea in mind that client can access enterprise systems at any time, from any where and by *any mobile device*. So, this tier encompasses different mobile devices like laptops, PDA's, mobile phones etc. with their respective browsers and GUI. As mobile devices equipped with different modern and old techniques which supports respective browsers and media formats, the need to support multiple marks up languages like WML, XHTML, and HTML etc. would increased in order to receive or display data on client's mobile devices. This tier supports these mark-up

languages and technologies and also designed to adopt with any new mobile technology without effecting on other tiers functionality and behavior. For example, if any new mobile device or technology will invent then only *request and response manager* components will update without affecting other components.

Unwired business logic tier: is further divided into two components i.e. *enterprise logic* and *rules manager*. The *enterprise logic* acts as enterprise core business logic and contains enterprise modules and sub modules like functional, supply chain management, human resource etc. these modules depends upon enterprise to enterprise and could change according to time and business needs.

The *rules manager* component is mainly answering the question of *how to deal or communicate with mobile users*. The *rules manager* contains following three sub components with their respective roles and functionalities:

- ***Request & response (R&R) manager:*** is used to take request and sending back response or feedback to respective mobile clients. This component determines the type of browser and the most necessary mobile device characteristics like displaying capabilities, device network, device region and many others. These characteristics help this component to display data on client's mobile device in more user friendly way. This component is designed by keeping *availability*, *security*, *reliability* and *adoptability* requirements because mobile client's start communication with system by passing his/her request to this component and this component will update if any new technology or device want to interact with the system to solve *adoptability* and *availability* issue, it allow only authenticated user's to log in using secure interface to solve *security* issue, and it also increase the speed of sending and receiving requests to solve *reliability* issue.
- ***Caching mechanism:*** is used to invoke business functions of enterprise systems and it also contain some enterprise business logics in order to fetch data from *cache* and if needed passing requests to *enterprise logic* component. This component solve *performance* issue because whenever client's pass their queries to the system, this component track record client's profile and response back fast by using *cache* component.
- ***Cache:*** is used as temporary storage of mobile client's data and the size of cache depend upon the size or need of an enterprise, if an enterprise is expecting large amount of mobile clients to access their enterprise system then the greater the size of cache would increase the overall performance of the framework and vice versa. Whenever mobile clients send his requests to the system, the system will check in cache first in order to get fast response.

Database tier: is used to store data. This framework is designed to support any third party relational data base management systems which give all data manipulation facility to users.

Display manager tier: is divided into two components i.e. XML converter and presentation manger, which is described as follows:

- **XML converter:** is used to convert data received from database into XML form. The idea of converting data into XML form is to address different mobile devices because data itself is device independent and XML is purely designed for mobile usage (*St.Laurent S., 2000*) which facilitates data exchange and transformation to other formats (*St.Laurent S., 2000*).
- **Presentation manager:** is used to adopt proper Cascading Style Sheet (CSS) (*St.Laurent S., 2000*) libraries on XML in order to present more user friendly data to mobile users. The selection of CSS libraries are based upon the type or characteristics received by *R&R manager* of mobile devices.

Each logical tier and their respective components are described above. The overall functionality of the framework for unwired enterprise systems is described in the following text. The framework is designed to support an idea that an enterprise wants to be accessed globally by different clients, with different mobile devices and by using different networks. That's why the framework supports almost all types of mobile devices accessing with different networks by using different technologies like WML, XHTML, HTML, WAP etc. and enough flexible to adopt with new technology or network.

In a real case, when a client wants to access unwired enterprise system it's request passes to *R&R manager* which identifies all necessary characteristics of mobile client like, clients region, device network, device displaying capacity, memory etc. the *R&R manager* will check *cache* in order to fetch client required data, if *R&R manger* finds the required data in cache, it responses back to respective client with required feedback, other wise it passes request to *cache mechanism* which tracks record of clients request and forwards it to *enterprise logic* component. The *enterprise logic* performs required business logic on request by using their business components like functional, human resource, supply chain etc. and pass it to the *database*. The framework could support any third party relational database management system like Oracle, SQL Server, My SQL etc which manipulate client data and send requested data to *XML converter*.

The XML converter makes an XML file of requested data and depending upon mobile device's characteristics the *presentation manager* puts additional CSS file on XML in order to present more user friendly data. After performing these activities the data reached in *cache* from where *R&R manger* fetches it and sends back to the client by using client's network.

6. Discussion

How can the designs of mobile aware software systems be improved? Two frameworks were selected and further discussed in order to investigate important design components of these frameworks (see chapter 4 for more details). The investigation of these components leads toward a new improved framework which has proposed in section 5.1. Based upon an evaluation criteria established in methodology chapter, both selected and proposed frameworks are evaluated and described in following table.

<i>Evaluated items</i>	<i>(Dabkowski A., et.al, 2003)</i>	<i>(Fagrell H., 2000)</i>	<i>Proposed framework</i>
<i>Availability:</i> is system available on different networks, technologies and networks.	Yes	Yes	Yes
<i>Security:</i> is system secure from misuse or loss of client's data.	No	No	Yes
<i>Reliability:</i> how efficient the system is responding accurate data to clients.	Yes	Yes	Yes
<i>Performance:</i> how quickly system responses to client's requests.	Yes	No	Yes
<i>Adoptive:</i> is system enough flexible to adopt with future needs and challenges	Yes	No	Yes

Table 2: the evaluation table of selected and proposed frameworks

The probability of the system is to operate at specific time depends upon various factors such as, types of mobile devices, technology used by mobile devices i.e. WAP, HTML etc, networks for communication i.e. LAN, WAN etc, geographical location of mobile client and many others. All these things are used to convey mobile client's request to the system and also affect the overall *availability* of the system. There are many types of mobile devices available in the market and many are in research and developments phase (Michael F., et.al, 2004). These devices lead towards new mobile technologies and networks and usually systems are designed to handle all current types of technologies and networks used by mobile client, and should also enough flexible to adopt with new technologies (Kumar S.M., et.al, 2001). In short, faster the request reach to the system, more fast the system should response back and *availability* ratio of the system should increase. It seems that there is a need of standardize technology which can bridge the gap of different devices, technologies and networks. All three frameworks satisfy *availability* item because their structures are designed to handle multiple devices, technologies and networks (Dabkowski A., et.al, 2003) (Fagrell H., 2000) and (see section 5.1), if any new device, technology or network tries to communicate with the system, it will only lead to update particular component of that framework without affecting other components of

that framework e.g. *request and response manager* component in the framework for unwired enterprise system (see section 5.1).

Is my data safe from misuse and loose? Is the main question arising in the mind of any mobile client and the importance of this question has increased for the system, when data is coming from different mobile clients at same time and from different locations. *Security* is the heart of any mobile system because it creates 'trust' among their mobile clients that their transaction would be safe and no one can damage their data (Ahonen P., et.al, 2005). This *trust* increases the ratio of total numbers of transaction made by one client and also increases the total numbers of clients of the system. Authentication and authorization are main method used by (Dabkowski A., et.al, 2003) and (Fagrell H., 2000) frameworks in order to provide security but author do not consider them enough for mobile usage as technology advancement had provides different hacking ways which can destroy or misuse mobile clients data (Security standard council, 2006). The proposed framework uses authentication and authorization techniques (see section 5.1), and besides that it also gives a secure interface to their mobile clients through which they start communication with the system and the system will track client's requests, responses, history and maintain their 'profile' for further correspondence.

The (Fagrell H., 2000) framework is purely designed for news journalism domain and is reliable only to that particular domain. While (Dabkowski A., et.al, 2003) framework and framework for unwired enterprise systems (see section 5.1) have *cache* component which increase systems performance under client's request's and for a specified period of time which increase the overall *reliability* of both frameworks.

The performance of the system depends upon various factors such as, device, technology and networks used by clients (Park S., et.al, 1998). And also internal structural of the system can also help to increase the overall performance of the system. The performance of (Fagrell H., 2000) framework is quite good in news journalism domain but author can not predict its performance on other domains as there is no real example to support. The (Dabkowski A., et.al, 2003) framework and framework for unwired enterprise systems (see section 5.1) both take client's requests and check required data in their own cache first, if they find required data in cache then they forward it to their respective clients and if they can not find required data in cache then they forward client's query to database. This internal structure of frameworks increases the overall performance of the system.

The rapid changes in businesses, trends, mobile devices, technologies, networks and many other forces which effects the overall functionality of enterprise systems and mobile usage is a major challenge for an architect to design a framework which can fit with current needs and are enough flexible to adopt with future changes (Roth V. 2004). The (Dabkowski A., et.al, 2003) framework and framework for unwired enterprise systems (see section 5.1) both are enough *adoptive* to meet future changes and challenges like, change in business requirements or change in mobile devices, technologies and networks. If any change occurs then respective components will be updated without affecting other components e.g. *enterprise logic* component of framework for unwired

enterprise system will change or update if any new business need occurs, this change will not affect other components functionality.

7. Summary and future work

In order to investigate important design components of mobile knowledge frameworks, two frameworks were selected, analyzed and discussed based upon news journalism domain requirements, this effort leads forwards to a new improved framework, called framework for unwired enterprise systems (*see section 5.1*). The proposed framework had designed and evaluated based upon some important issues like, reliability, security, adoptability, performance and availability. As mobile clients access these types of enterprise systems thorough different networks, technologies and by different devices, it is a big challenge to design a framework who handles multiple networks, technologies and networks, and it seems that there is a need of some standardizes technology or functionality which fills the gap between different technologies, devices and networks.

The next step is to implement this proposed framework into multiple mobile enterprise domains for better results and it will also mature the design of this framework. The author recommends using web services technique during implementation because it leads forward in the area of inter-enterprise cooperation and integration of different types of devices (*Dabkowski A., et.al, 2003*).

References

Dabkowski A. and Jankowska A.M. (2003). Comprehensive framework for mobile ERP system, Frankfurt, Europa-Universität Viadrina, available at <http://www.wiwi.euw-frankfurt-o.de/de/lehrstuhl/bwl/bi/mitarbeiter/jankowska/publikationen/index.html>

Fagrell F. (2000), Mobile knowledge, Göteborg, department of informatics.

Sobti S., Garg N., Zhang C., Yu X., Krishnamurthy A. and Randolph Y. Wang, PersonalRAID (2002), Mobile Storage for Distributed and Disconnected Computers, available at http://www.usenix.org/events/fast02/full_papers/sobti/sobti_html/index.html

Cohen D., Herscovici M., Petruschka Y., Yoëlle S.M., Soffer A., and Newbold D. (2002), Personalized pocket directories for mobile devices, available at <http://www2002.org/CDROM/refereed/92/>

Bär W. and Breunig M. (2005). Usage of mobile databases for mobile geoscientific applications, available at http://www.agile-secretariat.org/conference/estoril/papers/63_Wolfgang%20Bar.pdf

Michael F. Rogers (2004), Mobile Device Technology and Ergonomic Considerations Relevant to Wide Area Gaming.

Zhang T., Ying S., Cao S. and Jia X.Y (2006). A Modeling Framework for Service Oriented Architecture.

Alonso G and Casati F (2005), Web Services and Service-Oriented Architecture.

SAP (1972), Systems Application and Products, 15 Aug 2007, available at <http://www.sap.com/index.epx>

Kumar S.M and Bhargava B. (2001), a transaction model to improve data availability in mobile computing, available at <http://www.springerlink.com/content/mn166peej9m7a7de/>

Jun W., Shing-chi C, Huan Z., Xu W., Lijing and Yu-lin F. (2001), Modeling and verifying strong cache consistency for mobile data access, IEEE computer society.

Ahonen P., Eronen J., Holappa J., Kajava J., Kaksonen T., Karjalainen K., Karppinen K., Rapeli M., Rönning J., Sademies A., Savola R., Uusitalo I. and Wiander T. (2005), Information security threats and solutions in the mobile world, available at <http://www.vtt.fi/inf/pdf/tiedotteet/2005/T2308.pdf>

SAP white paper (2005), SAP system architecture overview, Chapter 1, pp 2-30.

Oracle corp (1977). Oracle, 15 Aug 2007, available at <http://www.oracle.com/index.html>

Oracle white paper (2005), Oracle collaboration suit, mobile collaboration, pp 7-24.

Compiere Inc, Compiere, 10 Aug 2007, available at <http://www.compiere.com/>

GNUe, GNU enterprise, 10 Aug 2007, available at <http://www.gnuenterprise.org/>

St.Laurent S. (2000), why XML, available at <http://www.simonstl.com/articles/whyxml.htm>

Myers M.D. (1997), Qualitative research in information systems, available at <http://www.qual.auckland.ac.nz/>

Wikipedia, Wikipedia the free encyclopedia, 10 Aug 2007, available at http://en.wikipedia.org/wiki/SAP_AG

MedLibrary.org, MedLibraray, 10 Aug 2007, available at http://medlibrary.org/medwiki/Enterprise_software

Komoda N. (2006), Service Oriented Architecture (SOA) in Industrial Systems.

Stal M. (2006), Using Architectural Patterns and Blue prints for Service-Oriented Architecture.

Security standard council (2006), Payment card industry (PCI) data security standard, available at <https://www.pcisecuritystandards.org/>

Mynttinen J. (2000), End-to-end security of mobile data in GSM, available at <http://www.tml.tkk.fi/Opinnot/Tik-110.501/2000/papers/mynttinen.pdf>

Park S., Song Y. and Cho D. (1998), Performance improvements of mobile data protocol in wire and wireless interworking environments, IEEE Xplore release 2.4, available at <http://ieeexplore.ieee.org/Xplore/login.jsp?url=/iel5/6295/16831/00776466.pdf>

Roth V. (2004), Obstacles to the adoption of mobile agent, IEE Xplore release 2.4, available at http://ieeexplore.ieee.org/xpl/freeabs_all.jsp?arnumber=1263076

ISWorld, Association for information systems, 15 Aug 2007, available at <http://www.isworld.org/Researchdesign/drisISworld.htm>

Oracle corp (1977), PeopleSoft, 15 Aug 2007, available at http://www.peoplesoft.com/corp/en/public_index.jsp

Oracle corp. (1977), JDEdwards, 15 Aug 2007, available at <http://www.oracle.com/applications/jdedwards-enterprise-one.html>

Oracle corp (1977). Siebel, 15 Aug 2007, available at <http://www.oracle.com/siebel/index.html>

OMA, Open Mobile Alliance, 13 Aug 2007, available at <http://www.openmobilealliance.org/>

Fernanado G.L and Francelin R.L (2005), A Service Oriented Architecture Applied to Artificial Neural Network.

Stojanovic Z., Dahanayake A. and Sole H.M (2004), Design of Service Oriented Architectures.

Perry R, and Lycett M. (2005), Service oriented Architecture.

P-IMAP, Push IMAP protocol, 15 Aug 2007, available at <http://db.org/2004/02/12/push-imap/>